

DRY MOUNTING PHOTOGRAPHS

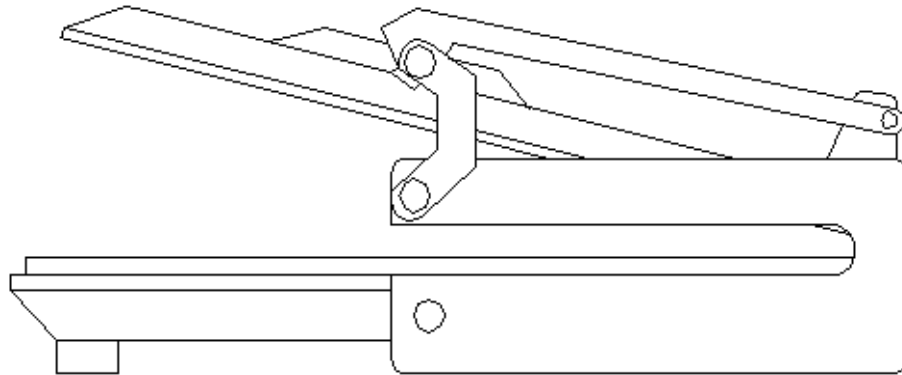

**THE TOOLS AND TECHNIQUES YOU
NEED TO MASTER THE DRY MOUNTING
PROCESS**

by
J.B. Harlin

**J.B. Harlin, Photographer
Benbrook, Texas**

DRY MOUNTING PHOTOGRAPHS

Published, designed, and produced by:

J.B. Harlin, Photographer
P.O. Box 26994
Benbrook, TX 76126

For comments, questions, or inquires contact:

J.B. Harlin
P.O. Box 26994
Benbrook, TX 76126
E-Mail: jbharlin@jbhphoto.com
Web Page: www.jbhphoto.com

Printed in the United States of America

Copyright ©1998 by J.B. Harlin. All rights reserved.

No part of this book may be reprinted, or reproduced, or utilized in any form or by any electronic, mechanical or other means, now known or hereafter invented, including photocopying and recording, or in any information storage and retrieval system, without permission in writing from the publisher.

Limits of Liability and Disclaimer of Warranty

The author and publisher have used their best efforts in preparing this book. The author and publisher make no warranty of any kind, expressed or implied, with regard to the instructions and suggestions contained in this book. The author and publisher shall not be liable in the event of incidental or consequential damages in connection with, or arising out of, the furnishing, performance or use of these instructions.

First Printing--May 1998

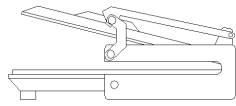

DRY MOUNTING PHOTOGRAPHS

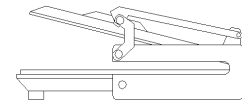

When it comes to the photographic print, presentation is indeed very important. Each step in the photographic process leads to the next, then finally ends in the finished product. In reality, each step is as important as any other. From finding the image, to processing the film, to presentation—*each step must be done with care and precision*. I feel that dry mounting of photographic prints is by far the cleanest and most permanent presentation technique available. It has been used for many years by all of the great masters of photography, and is still widely used.

The process of dry mounting is not difficult to learn if you follow a few simple rules. With a little practice you will soon become an expert. A word of caution is in order here—*start with some old scrap or work prints*. Do a little experimenting before you try to mount a good print. You will find you may need to make a few adjustments as you learn the materials and techniques required. Be patient, experiment, and you will soon master the art of dry mounting. There is a learning curve that takes a little time, so do not become discouraged. You will ruin a few prints, but your mistakes will guide you to mastery of the dry mount process.

I am going to describe my method of dry mounting. This is not the only way to do it, but I think you will find it works very well.

MATERIALS AND TOOLS

The dry mounting process is actually quite simple. At the heart of the process is the dry mount tissue. This material is nothing more than a piece of thin tissue paper that has been treated on both sides with a heat-activated adhesive. When the tissue is heated to around 200 degrees F, the adhesive melts and forms a bond.

The most complicated piece of equipment needed is the dry mount press. This is a large mechanical press with a rubber mat on its base, and a large smooth heated metal plate that can be lowered and clamped onto the rubber mat. The metal plate is called the *platen*, and is heated by internal heaters that are controlled by a thermostat. The press has a handle that is used to raise and lower the platen. This handle is called the *lever arm*. When the press is closed the platen is lowered and then clamped to apply pressure to the materials placed on the lower rubber pad.

A small hand-held heated iron called a *tacking iron* is needed to tack the dry mount tissue into place. Once the print is positioned on the mount board, the tacking iron is used to tack the corner of the dry mount tissue to keep everything aligned while it is readied for the dry mount press.

You will need a good paper trimmer to trim your prints. I recommend you use a *rotary trimmer* when trimming photographs. The guillotine-type paper cutters tend to shatter the emulsion edge. They also tend to pull the material and not give straight edges.

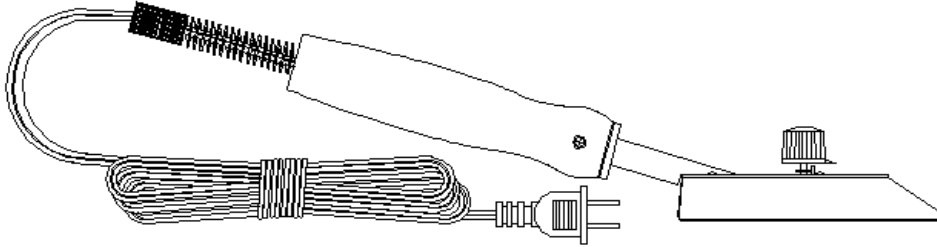

Figure 1

A tacking iron is a small hand held heated iron. It is used to tack the dry mount tissue to the photograph and the mount board. This holds the assembly together prior to placing in the dry mount press.

These are the basic tools required for dry mounting. There are a few other small items that make the job a little easier and I will describe them as I go along.

PROCESS OVERVIEW

The first step is to dry both the print and the backing material. All paper products absorb some amount of moisture. Moisture causes the paper to swell. Drying the photograph and mount board for about 30 seconds in the dry mount press helps to keep the finished mount flat. *It is very important that both the photograph and the mounting material be dried before mounting.*

The photograph can shrink in physical size when it is heated in the dry mount press. If the dry mount tissue is tacked to the print then trimmed without drying the print first, this can cause the dry mount tissue to protrude beyond the photograph edge. This will leave a small line of exposed adhesive around the photograph which will adhere to the cover board and ruin the entire assembly.

After drying the photograph, a sheet of dry mount tissue is first tacked to the back of the print with the heated tacking iron. The print and attached dry mount tissue is then trimmed to the final dimension. This places the dry mount tissue to the very edge of the print. Having the dry mount tissue extend to the edge of the print will insure that the entire area of the print will lie flat on the mount board when the mounting process is completed.

The trimmed print is then positioned onto the mount board. Two corners of the print are gently lifted and the tacking iron is used to tack the corners of the dry mount tissue to the mount board. The assembled sandwich, made up of the dry mount tissue between the print and the mount board, is then placed into the heated dry mount press. When the dry mount press is closed, heat and pressure are

applied to the sandwich. The heat activates the adhesive contained in the dry mount tissue, and the pressure bonds the print and the backing together.

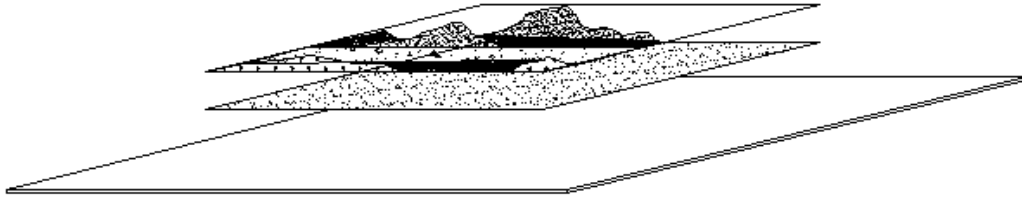

Figure 2

The dry mount sandwich consists of the photograph, dry mount tissue and the mount board.

The mounted print is then removed from the dry mount press, and after cooling a neat, clean, bond is achieved. The print is flat and ready for display.

DETAILED DRY MOUNTING PROCEDURE

Nothing is more infuriating than ruining a beautiful print. *It is best if you are just learning to dry mount to use scrap prints until you get the hang of it.* There are a few tricks and pit falls to watch out for. Even after years of experience you will ruin a print every now and then. The key to success is being very meticulous and taking your time. Do not ruin a print in the last step by being careless or hurrying.

GETTING STARTED

The first thing I do is turn on the dry mount press and set the correct temperature. Check the data sheet that comes with the dry mount tissue for correct temperature and mounting time. Also turn on the tacking iron. Let the press stabilize for at least 15 minutes. It is better if you wait 30 minutes. This allows the platen to reach the correct temperature and remain there without wide variations that could effect the strength of the dry mount tissue bond.

I place two large pieces of mat board in the press. These are 2-ply board that is cut the same size as the platen. I use these on either side of the mount sandwich for protection. The standard procedure outlined by most manufacturers is to use release tissue between your work and the platen. I do not do this since I feel the release tissue does not offer enough protection for the delicate emulsion of the photograph. If there is the slightest flaw in the platen it will mar the print surface. I feel more secure using the mat board since I can see it and clean it before I place it over the photograph.

CAUTION: *Never place a photograph into the press without some form of cover between the photograph and the heated platen. You can damage your*

photograph, but even worse, if the adhesive contained in the dry mount tissue is over heated it could run out around the edges of the print. This will bond the photograph and mat to the platen. The press will have to be disassemble and the platen cleaned. You do not want this to happen.

Once the press begins to cycle I close it on the backing boards and leave them there for about 2 minutes. Then I open the press and allow them to cool. This drives out any moisture that may have accumulated in the board.

If you are mounting fiber base prints, you should heat each print before mounting for about 30 seconds to dry them also. The print size can actually vary with the amount of moisture contained in the paper. If you apply the mount tissue to the print without first drying it, the print can shrink when heat is applied. This will allow the mounting tissue to protrude beyond the print edge and ruin the print and mount board. It is also a good idea to place the mount board into the press for about 1 minute to dry it also. The idea is to get all of the materials to the same moisture content before you begin.

PREPARING THE PRINT

As I said above, it is a good idea to dry your prints before mounting. This is easy to do, just place the print between the backing sheets and close the press for about 30 seconds. Then remove the print and allow it to cool.

You will need a clean smooth work area. It is a good idea to use another piece of mat board for a work surface. It is all too easy to damage a print when you lay it face down to tack the dry mount tissue to the back.

Place the print face down on a clean sheet of mat board. Carefully dust off the back of the print and check for any particles of dirt. Remember that anything under the print will show on the surface as a bump and ruin the print. You must be very meticulous about keeping everything very clean. I wear a cotton glove on one hand while mounting. I will use a fox tail drafting brush and my gloved hand to make sure every surface is perfectly clean.

Now lay a sheet of dry mount tissue on the back of the print. Align it so it covers the entire photograph, then tack it into place using the tacking iron. Hold the tissue firmly with one hand and slowly draw the iron from the center of the print to the center of one edge. Stop before you get to the edge or you will drag adhesive onto your work surface and it will get on the front of the next print you mount. Then rotate 90 degrees and repeat. Draw the iron from the center of the print to the center of all 4 sides (see Figure 3).

NOTE: *DO NOT* try to short cut and drag the iron all the way from one side to the other. You will wrinkle the mount tissue and ruin the print.

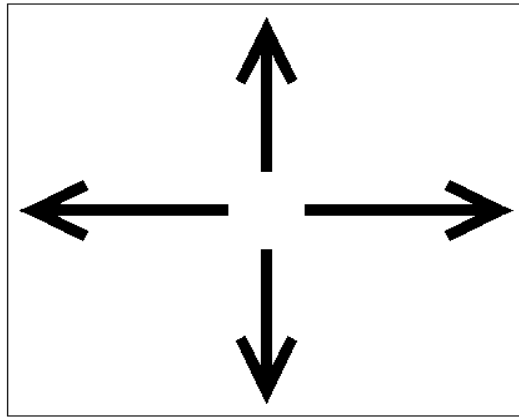

Figure 3

When tacking the dry mount tissue to the back of the print, always start near the center of the photograph and slowly drag the tacking iron toward the edge. Stop before reaching the edge or you will drag the melted adhesive onto the work surface and ruin the next print.

Next you must trim the print and mount tissue to its final size. It is always best to use a rotary trimmer to trim prints. Place the print face up into the trimmer, hold firmly and trim each side. When you are finished the dry mount tissue should be flush with each edge. If the tissue does not come all the way to the edge you must trim more of the print. ***The tissue must come flush to each edge or the print will not lay flat.***

You now have your print ready to position onto the mount.

MAKING THE SANDWICH

If you haven't already done so, place the mount board into the press and heat it for about 1 minute, then allow it to cool. This will drive out any moisture in the mount board. Before you position the print on the mount board, be sure to check the mount board and the back of the print for dust and grit. Again, I use the fox tail brush and then my gloved hand. Remember, *everything must be clean.*

The most important thing you have to do now is get the photograph positioned on the mount board. It must be straight and centered. You may want to experiment with how you place your print on the mount board. Some like to leave more space at the bottom than the top. I do not like this. I mount everything dead in the center; left, right, up, down. This is the only way for me. You choose what suits you.

In any event, you must get the print aligned with the edges of the mount board. Nothing is more frustrating than to take the mounted print out of the press and

discover the print is crooked. About the only thing you can do is trim the mount board back to square with the print. The basic idea is to get it right the first try.

A drafting board and T-square are invaluable tools for print positioning. If you use a ruler and a marker to mark off the distance from the center of the T-square toward either end, you can use this scale to center the print. Zone VI used to make such a mounting device specifically for this purpose. You can search the Internet and usually find a used Zone VI Dry Mount Jig, or you can make your own from a drafting board and square. The mounting jig is invaluable for print positioning.

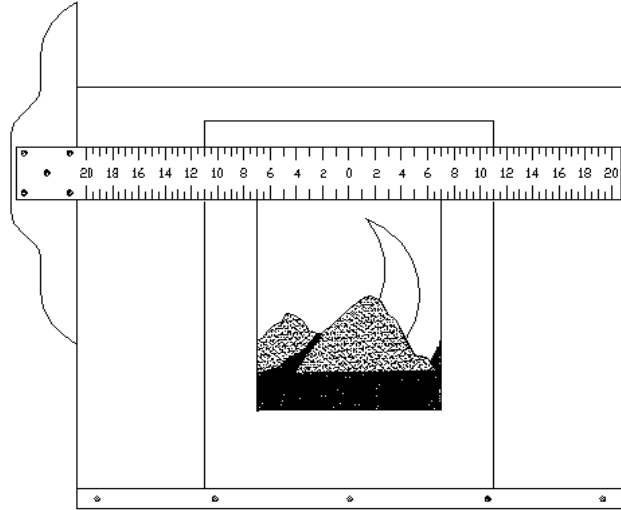

Figure 4

A modified drafting T-square and drafting board allows the print to be centered on the mount board. This device also assures that the photograph is aligned squarely on the mount board.

Once I get the print positioned on the mount board I use a weight bag to hold the print and keep it from moving. (I use a soft lens pouch filled with pennies for a weight bag.) Now lift up one corner of the print. Be careful to leave the dry mount tissue against the mount board. Carefully slide the tacking iron between the print and the dry mount tissue and tack the tissue to the mount board. Be extremely careful not to drag the iron to the edge of the tissue and smear the adhesive onto the mount board. Now tack the opposite corner and remove the weight bag. I usually tack the left and right bottom corners.

You now have your mount sandwich assembled and ready for the mount press.

USING THE DRY MOUNT PRESS

Now we are ready to place the sandwich into the press and do the actual mounting. The thing to watch out for here again is dirt. I have a small compressor in our print mounting area and I use a few blasts of air to remove any dirt or grit from the face of the print. You could use a very soft anti-static film brush to gently clean the

emulsion of the print. Be very careful here, a stiff bristle brush is too coarse and can scratch the print surface.

I place the sandwich on the bottom backing board, print facing up. Then I meticulously clean the upper board before laying it over the photo. This entire assembly goes into the dry mount press, photo side up toward the platen. Center the assembly under the platen, close the press and start timing.

NOTE: *I have found that using the cover board adds about 25% to the mounting time. You may want to try the manufacturer's recommended time to start with, but you probably will have to add some time.*

When time is up, open the press and remove the mounted print. I like to cool the print under pressure to insure a good bond. I place the mounted print face up on a smooth surface and cover with a large piece of 1/4" plate glass. It only takes about a minute to cool.

When the print cools you will need to check the bond. Gently bend one corner of the mount board away from the print. You will quickly find out if the tissue bonded with the materials. If insufficient heat was used, the print will pop away from the mount board. If this is the case you only need to place it back into the press and try again. Add 25% to the previous time and check again when cool.

NOTE: *It is a good idea once you finish mounting to stack all of your mounted prints and place a weight on the stack and leave them for a day or two. I use a large sheet of 1/4 inch plate glass for a weight. This will make the mount board and print lie flat.*

You should now have a beautifully dry mounted print.

REPAIRING DAMAGED PRINTS

One of the biggest problems in dry mounting is dirt. If a speck of dust is trapped between the photograph and the mount board, a bump will be left in the print surface. This is the most difficult defect to repair and requires a very delicate touch and much patience. You can smooth out the bump in the emulsion surface using a smooth rounded object. I have read of people using the cap from a Bic™ pin. I prefer to use a burnishing bone. This is a polished piece of bone especially designed for smoothing and creasing paper.

Begin by gently applying pressure to the raised area of the emulsion. Work very slowly and carefully. Rotate the print and view it from different angles under direct light. By gently pressing on the raised area you can slowly work the print surface back down, thus repairing the defect.

This procedure takes some practice, but soon you will be able to repair any bumps in the print surface. Remember to work very slowly and examine the area closely and from several different viewing angles.

NOTE: *Light Impressions sells the burnishing bone I described above. I use the point shaped 6" style, catalog #2331.*

The other dirt problem is a particle between the emulsion and the cover sheet. This will leave a small crater in the surface of the print. This can be coaxed out with a little wetting agent and distilled water. Make a mixture of distilled water and wetting agent, the same you would use for print spotting. Using a fine #0000 spotting brush, apply a drop of water to the dent. The water will swell the emulsion and when dry the crater will be gone.

I have found that by applying a large drop of water (enough to more than cover the crater) and allowing it to dry will remove most of the crater. Then applying just enough to fill the remaining dent will slowly work the last of the indentation out. You probably will have to repeat this several times.

Remember, the best thing is to keep everything clean and avoid these problems in the first place. You must be meticulously alert to possible damage to the photograph. Take your time and do not get in too big a hurry. You are more prone to make mistakes if you rush. By the time you get to print finishing, you have a lot invested in both time and money. Care will make everything go smooth.

HINT: *You need a good magnifier for repairing surface damage. I use an OptiVISOR™ with maximum magnification. This is a hood-type visor that flips down for critical viewing. Many jewelers use them. Check your local hardware store or hobby shop for availability.*

A FEW THOUGHTS AND TIPS

Congratulations! You are now a dry mount expert. Remember, you will make a few mistakes here and there. If you make your own prints it is always good practice to make a couple of extra, just in case of accident. I guarantee, *you will ruin a print now and then.*

Be prepared to make mistakes. I have already said it several times, and I will say it again; *when you first begin learning to dry mount, practice on scrap prints.*

Once your print is mounted you can add an over mat, or just leave it float mounted. Remember, if you plan to place the photograph into a frame you must keep the print surface from contacting the glazing. A window mat is the easiest way to prevent this from happening.

NOTE: *For a more detailed discussion see the pamphlet **MATTING & FRAMING B&W PHOTOGRAPHS.***

I prefer to use 4-ply mount board for both backing and mat. Some recommend you use 2-ply for the mount board and 4-ply for mat. I like the added weight of the 4-ply material. You should be the judge of what suits you.

While on the subject of mat board, I recommend you use only the highest grade, 100% rag, archival materials. You should always use archival materials for long-term stability. I use materials sold by *Light Impressions*, and feel their products are of the highest quality.

I hope I have given you a head start on learning how to dry mount your photographs. With a little practice you will soon be able to mount your work and display it using this wonderful method. I wish you all the luck in the world.

www.jbhphoto.com



DRY MOUNTING PHOTOGRAPHS

BY
J.B. HARLIN

FROM THE SERIES
**MASTERING THE CRAFT OF FINE ART
PHOTOGRAPHY**

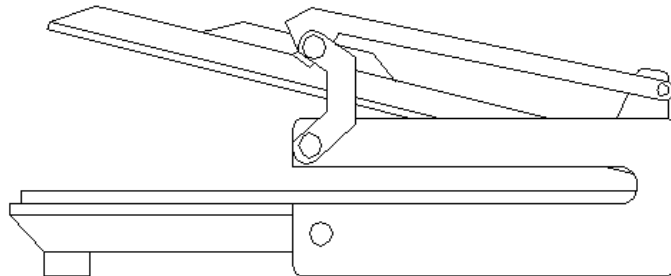

A TRUE CRAFTSMAN IS THE MASTER OF HIS TOOLS.

**THIS MANUAL IS ONE IN A SERIES OF HOW-TO BOOKLETS
WRITTEN TO HELP YOU IMPROVE YOUR PHOTOGRAPHIC SKILLS.**

Published by
J.B. Harlin, Photographer
P.O. Box 26994
Benbrook, TX 76126
E-Mail: jbharlin@jbhphoto.com
Web Page: www.jbhphoto.com

